

DS6040 MARKING HEAD

Marking head for deep marking and ideal for integration systems. Compact and economical. Patented technology "**Differential System**®".

CHARACTERISTICS

- 60 x 40 mm marking area.
- For working on industrial environments.
- Electromagnetic or pneumatic pin activation (4-6 bar).
- Speed up to 12 characters/second.
- Pneumatic pin activation: N14,N14G,N20,N20G.
- Electromagnetic stylus: S4.
- 3,5-meter robotics cable with AMPHENOL connector, with customisation possibilities.
- Fixed bench and electric bench (optional).
- Screwball micrometric (optional).
- Protection system (optional).
- Connetion with CYMAQ control unit: AS200,AS400.
- Low maintenance.

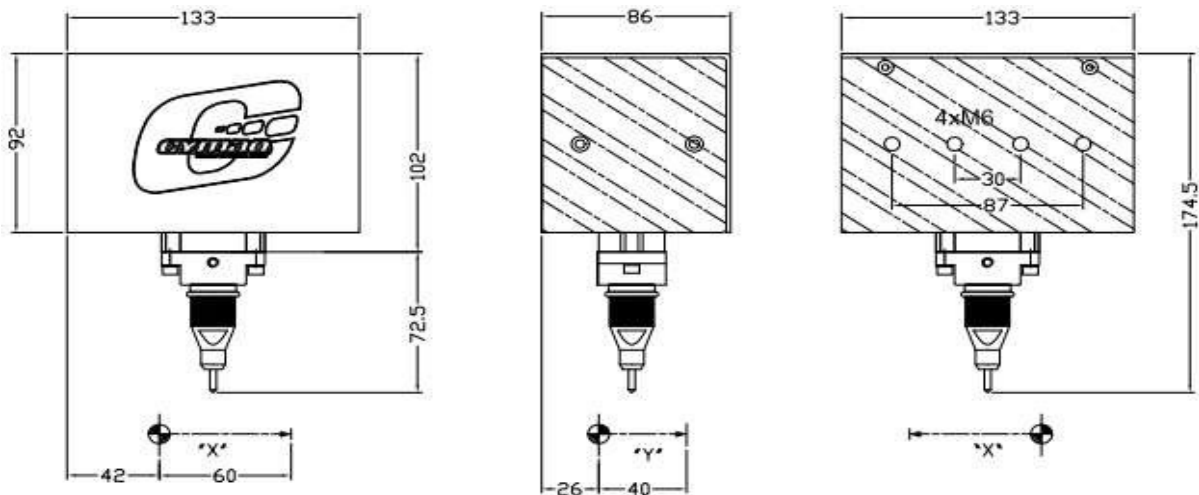

Area	Dimensions (mm)			Weight	
	X x Y	Width	Depth		Height
60 x 40		133	86	174,5	1,7