

ML1711 MARKING HEAD

Marking head for deep marking of large parts and ideal for integration systems.

CHARACTERISTICS

- 170 x 110 mm marking area.
- For working on industrial environments.
- Electromagnetic or pneumatic pin activation (4-6 bar).
- Speed up to 7,5 characters/second.
- Pneumatic pin activation: N14,N14G,N20,N20G,N34.
- Electromagnetic pin activation: S6.
- 3,5-meter robotics cable,with customisation possibilities.
- Electric bench (optional).
- Screwball micrometric (optional).
- Protection system (optional).
- Connection with CYMAQ control unit: AS200,AS400.
- Low maintenance.

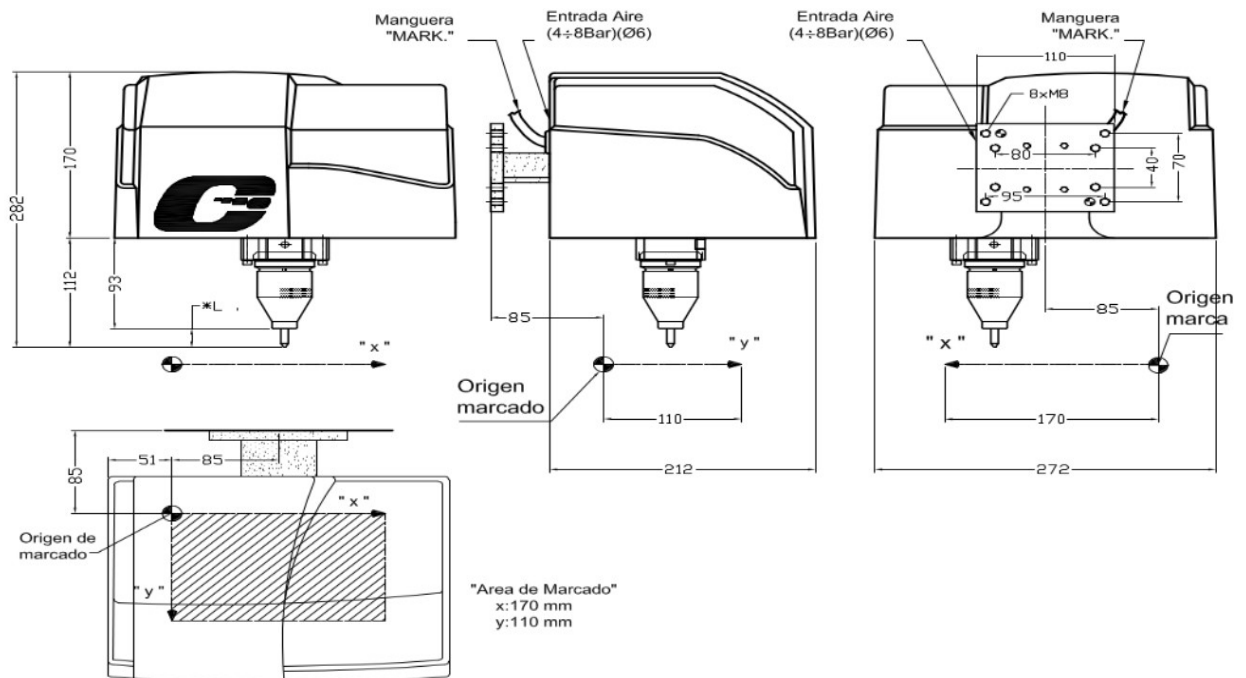

Area	Dimensions (mm)			Weight Kg
	Width	Depth	Height	
X x Y	272	212	282	7,5